

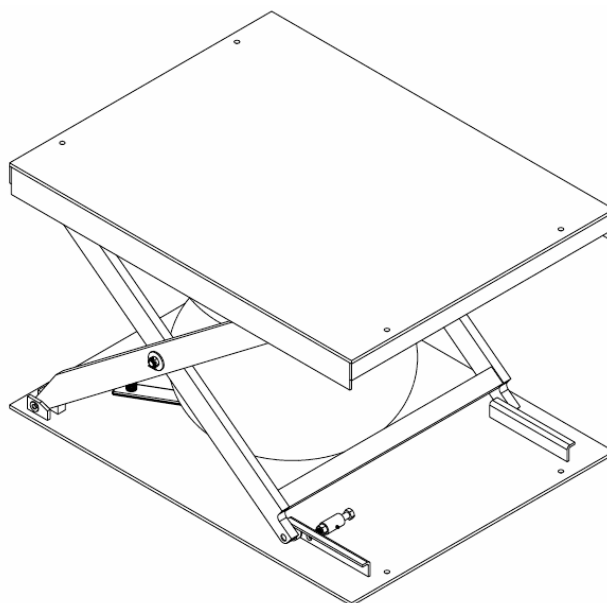

VESTIL MANUFACTURING CORP.

2999 North Wayne Street, P.O. Box 507, Angola, IN 46703
 Telephone: (260) 665-7586 -or- Toll Free (800) 348-0868
 Fax: (260) 665-1339
 www.vestilmfg.com e-mail: sales@vestil.com

ABLT-H-LP SERIES AIR BAG LIFT TABLES
INSTRUCTION MANUAL



Receiving instructions:

After delivery, IMMEDIATELY remove the packaging from the Hook-Base in a manner that preserves the packaging and maintains the orientation of the product in the packaging; then inspect the product closely to determine whether it sustained damage during transport. **If damage is discovered during the inspection, immediately record a complete description of the damage on the bill of lading.** If the product is undamaged, discard the packaging.

NOTES:

- 1) Compliance with laws, regulations, codes, and non-voluntary standards enforced in the location where the product is *used* is exclusively the responsibility of the owner/end-user.
- 2) VESTIL is **not liable** for any injury or property damage that occurs as a consequence of failing to apply either:
 - a) the instructions in this manual; or b) information provided on labels affixed to the product. Neither is Vestil responsible for *any* consequential damages sustained as a result of failing to exercise sound judgment while assembling, installing, using or maintaining this product.

Table of Contents

Hazard identification: explanation of signal words.....	2
Safety Guidelines.....	2
Product specifications by model.....	3
Installation.....	3
Operation.....	3
Maintenance.....	3-4
Limited warranty.....	5

Hazard Identification--Explanation of SIGNAL WORDS

This manual uses SIGNAL WORDS to indicate the likelihood of personal injuries, as well as the probable seriousness of those injuries, if the product is misused in the ways described. Other signal words call attention to uses of the product likely cause property damage.

The signal words used appear below along with the meaning of each word:



Identifies a hazardous situation which, if not avoided, **WILL** result in **DEATH** or **SERIOUS INJURY**. Use of this signal word is limited to the most extreme situations.



Identifies a hazardous situation which, if not avoided, **COULD** result in **DEATH** or **SERIOUS INJURY**.



Indicates a hazardous situation which, if not avoided, **COULD** result in **MINOR** or **MODERATE** injury.



Identifies practices likely to result in product/property damage, such as operation that might damage the product.

Each person who assembles, installs, uses, or maintains this product should read the entire manual **in advance and fully understand the directions**. **If after reading the manual you do not understand an instruction, ask your supervisor or employer for clarification, because failure to adhere to the directions in this manual might result in serious personal injury.**

SAFETY GUIDELINES

Vestil diligently strives to identify foreseeable hazards associated with the use of its products. However, material handling is inherently dangerous and no manual can address every conceivable risk. The end-user ultimately is responsible for exercising sound judgment at all times.



Electrocution might result if any part of the lift table or work piece placed on the table contacts electrified wires. Reduce the likelihood of electrocution by applying **common sense**:

- DO NOT *contact* electrified wires with any part of the table or the load/work piece on it;
- Install the table in a location where contact with electrified wires will not occur.



If this product is used improperly or carelessly, the operator and/or bystanders might sustain serious personal injuries or even be killed. **ALWAYS** use the product properly:

- ***Failure to read and understand the entire manual before assembling, installing, using or servicing the product constitutes misuse.*** Read the manual to refresh your understanding of proper use and maintenance procedures.
- DO NOT exceed the maximum rated load.
- Inspect the lift table before each use. DO NOT use this device if the inspection reveals structural damage. Examples of structural damage include: 1) broken, missing, or deformed legs; 2) damaged, deformed or ruptured air bladder; 3) cracked welds; 4) enlarged openings for fasteners at pivot points; 5) corrosion, severe wear, or other condition that affects the ability of the product to support applied weight or itself; 6) damaged, deformed or cracked roller channels. Immediately lock out a tag out the lift table and replace each part that fails to pass an inspection. DO NOT use the product until it is fully restored to normal condition. ONLY use manufacturer-approved replacement parts.
- DO NOT use the product if any unusual noise or movement is observed. If a malfunction occurs, remove the unit from service and notify your supervisor or maintenance personnel about the issue.
- DO NOT bypass or attempt to bypass the safety lock system.
- DO NOT tamper with the pressure relief valve system.
- DO NOT use the lift table UNLESS it is securely anchored to the ground.
- ALWAYS evenly distribute and center the load on the table.
- DO NOT remove or obscure any label. All product labels must be readable and undamaged.
- DO NOT use the table to lift or support people.
- DO NOT modify the table in any way UNLESS you first obtain written approval from Vestil. **Unauthorized modifications automatically void the limited warranty (see p. 5) and might make the table unsafe to use.**
- DO NOT use the table UNLESS all product labels are readable and undamaged.



Proper use, maintenance, and storage are essential for this product to function properly.

- Always use this product in accordance with the instructions in this manual and consistent with any training relevant to scissor lift tables.
- Keep the lift table clean & dry.

Product Specifications by Model:

Model	Capacity in pounds (kg)	Lowered height in Inches (cm)	Raised height in Inches (cm)	Net Weight in Pounds (kg)
ABLT-H-LP-1-29	1,000 (~455kg)	4 ¹ / ₈ in. (~10.5cm)	29in. (~73.7cm)	550 pounds (250kg)
ABLT-H-LP-2-29	2,000 (~909kg)	4 ¹ / ₈ in. (~10.5cm)	29in. (~73.7cm)	560 pounds (254.5kg)
ABLT-H-LP-3-29	3,000 (~1,364kg)	4 ¹ / ₈ in. (~10.5cm)	29in. (~73.7cm)	570 pounds (259kg)
ABLT-H-LP-4-29	4,000 (~1,818kg)	4 ¹ / ₈ in. (~10.5cm)	29in. (~73.7cm)	580 pounds (264kg)
ABLT-H-LP-6-23	6,000 (~2,727kg)	4 ¹ / ₈ in. (~10.5cm)	23in. (~58.4cm)	590 pounds (268.2kg)

NOTE: Air supply pressure should be at least 60psi and no more than 120psi.

Installation

1. Install the lift table on a level, even surface. Anchor the table to the floor with appropriately-matched anchor bolts. Measure the diameter of the bolt holes in the base of the frame, and install bolts that are at least 4in. long to anchor the table to the floor.
2. Shim the table to level it if necessary.
NOTE: Grout should be placed under the table base to resist warping and bending forces applied to the base between shims. Grout around the entire perimeter of the base frame.
3. Connect main air supply to the control pedestal. If no control pedestal is supplied, see schematic for air inlet.

NOTE: Use only clean, dry air. Use of a filter/regulator is recommended.

Lift Table Operation

1. To raise the table.
 - a. Press the lever on the control pedestal to the "UP" position.
 - b. Release the lever as soon as the table reaches the desired height.
2. To lower the lift.
 - a. Press the lever on the control pedestal to the "DOWN" position.

Maintenance:

Install the maintenance stop before inspecting or maintaining the table. Maintenance stop installation is explained in FIG. 3 below. [NOTE: When performing maintenance beyond merely applying lubrication to outer surfaces, use overhead rigging to secure the tabletop.]

FIG. 3: Maintenance prop installation

- 1) Unload the table; then fully raise the table.
- 2) Loosen the set screw using a ³/₃₂in. Allen wrench.
- 3) Press the safety stop bolt through the roller guide; then retighten the set screw.
- 4) Lower the table until the roller rests against the safety stop bolt.

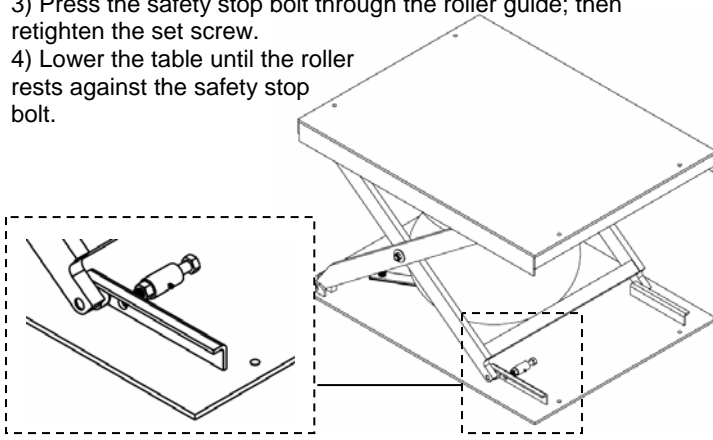
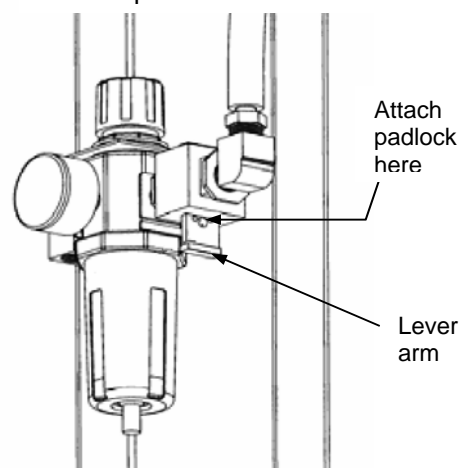

FIG. 4: LOCKOUT attachment point



1. Check clamps and hose connections periodically. Verify that all connections are airtight.
2. Inspect all moving parts to confirm normal motion, cleanliness, and state of wear. If any part is excessively worn, immediately tag the unit "OUT OF SERVICE" and report the issue to maintenance personnel.

LOCKOUT/TAGOUT Procedure: Press the lever arm down to cut off air to the system (see FIG. 4 on p. 3); then attach a padlock to the lever arm through the opening in the lever arm.

3. Clean the air filter element at least every 3 months.
4. Grease and oil all pivot points and shafts at least every 3 months. Lubricate all pivot points at least once per day if the table is in high cycle operation. Use 90-weight gear lube (SAE 85W 140 EP) to lubricate pivots and shafts.
5. Grease the upper and lower roller channels.
6. Lubricate pivot points of the lock mechanism.

LIMITED WARRANTY

Vestil Manufacturing Corporation ("Vestil") warrants this product to be free of defects in material and workmanship during the warranty period. *Our warranty obligation is to provide a replacement for a defective original part if the part is covered by the warranty, after we receive a proper request from the warrantee (you) for warranty service.*

Who may request service?

Only a warrantee may request service. *You are a warrantee if* you purchased the product from Vestil or from an authorized distributor AND Vestil has been fully paid.

What is an "original part"?

An original part is a part used to make the product as shipped to the warrantee.

What is a "proper request"?

A request for warranty service is proper if Vestil receives: 1) a photocopy of the Customer Invoice that displays the shipping date; AND 2) a written request for warranty service including your name and phone number. Send requests by any of the following methods:

Mail
Vestil Manufacturing Corporation
2999 North Wayne Street, PO Box 507
Angola, IN 46703

Fax
(260) 665-1339
Phone
(260) 665-7586

Email
sales@vestil.com

In the written request, list the parts believed to be defective and include the address where replacements should be delivered.

What is covered under the warranty?

After Vestil receives your request for warranty service, an authorized representative will contact you to determine whether your claim is covered by the warranty. Before providing warranty service, Vestil may require you to send the entire product, or just the defective part or parts, to its facility in Angola, IN. The warranty covers defects in the following *original* dynamic components: motors, hydraulic pumps, electronic controllers, switches and cylinders. It also covers defects in *original* parts that wear under normal usage conditions ("wearing parts"), such as bearings, hoses, wheels, seals, brushes, and batteries.

How long is the warranty period?

The warranty period for original components is 1 year. The warranty period begins on the date when Vestil ships the product to the warrantee. If the product was purchased from an authorized distributor, the period begins when the distributor ships the product. Vestil may extend the warranty period for products shipped from authorized distributors by *up to* 30 days to account for shipping time.

If a defective part is covered by the warranty, what will Vestil do to correct the problem?

Vestil will provide an appropriate replacement for any *covered* part. An authorized representative of Vestil will contact you to discuss your claim.

What is not covered by the warranty?

1. Labor;
2. Freight;
3. Occurrence of any of the following, which automatically voids the warranty:
 - Product misuse;
 - Negligent operation or repair;
 - Corrosion or use in corrosive environments;
 - Inadequate or improper maintenance;
 - Damage sustained during shipping;
 - Collisions or other incidental contacts causing damage to the product;
 - Unauthorized modifications: DO NOT modify the product IN ANY WAY without first receiving written authorization from Vestil. Modification(s) might make the product unsafe to use or might cause excessive and/or abnormal wear.

Do any other warranties apply to the product?

Vestil Manufacturing Corp. makes no other express warranties. All implied warranties are disclaimed to the extent allowed by law. Any implied warranty not disclaimed is limited in scope to the terms of this Limited Warranty.

