



STANDARD AIR LIFT

INSTRUCTIONS • PARTS DRAWING • PARTS LIST

PN# 10740 -16749 -16600 - 10741

WARNING: READ INSTRUCTIONS BEFORE OPERATING

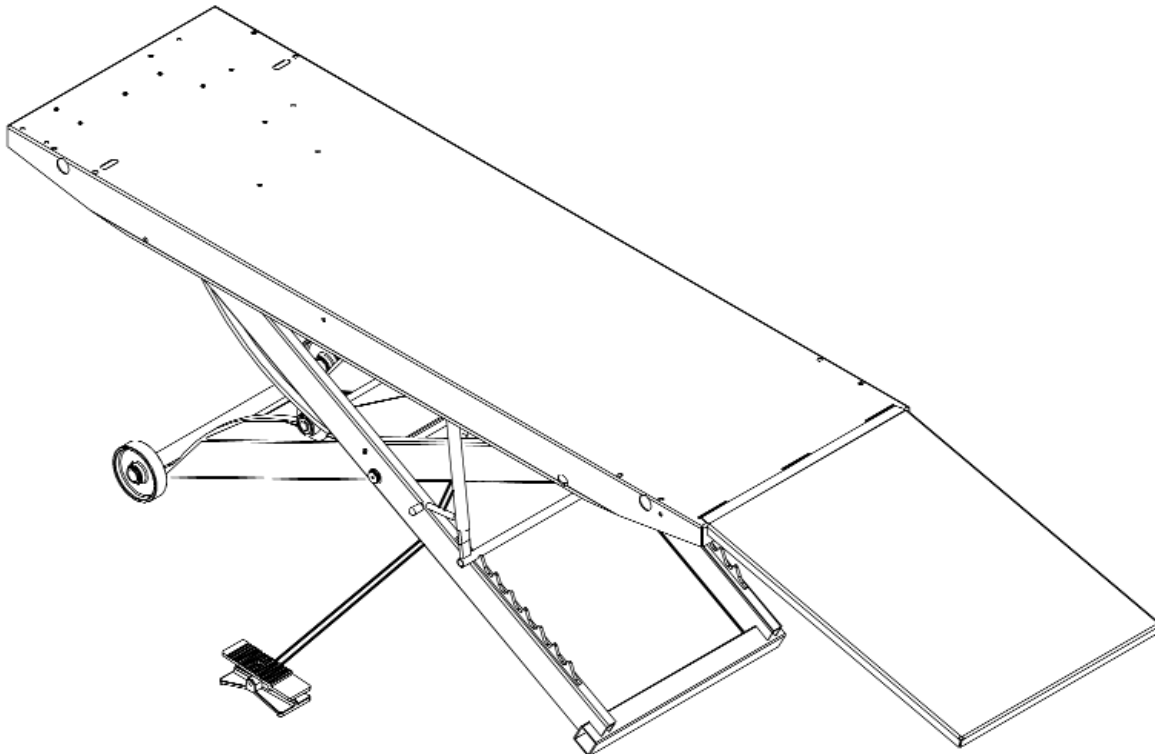

- 1. Center load on table - 1000 lb. maximum.**
- 2. Connect to 110 psi maximum shop air.**
- 3. Keep safety bar in position at all times - except when lowering.**
- 4. Keep hands and tools from under carriage.**
- 5. Do not mount table when in elevated position.**
- 6. Do not ride vehicle onto lift.**
- 7. Lift must be in the lowered position when moving.**
- 8. Only trained persons should operate Air Lift.**
- 9. The working area should be sufficiently lit.**
- 10. Foot controller should be at least 3 feet away from Air Lift during raising and lowering operation.**
- 11. Recommended for indoor use only.**

HANDY DIVISION OF JADEIM, LLC

401 South 2nd. Marshalltown, IA 50158 Ph: 855-752-5446 Fax 641-752-1205 www.handyindustries.com



STANDARD AIR LIFT



NOTE: READ ENTIRE MANUAL TO COMPLY WITH ALL SAFETY AND SERVICE PRECAUTIONS. DEATH, PERSONAL INJURY AND/OR PROPERTY DAMAGE MAY OCCUR UNLESS INSTRUCTIONS ARE FOLLOWED CAREFULLY.

INSTRUCTIONS

UNPACKING AND SET-UP

1. Open carton, then remove ramp, and shipping boards.
 - ➡ 2. CAREFULLY TURN TABLE UPRIGHT INTO OPERATING POSITION BEFORE REMOVING SHIPPING CABLE RESTRAINT FROM SCISSOR MECHANISM.
 - ⚠ 3. Connect foot-operated air valve to 110 psi air supply. The lift may be damaged and/or personal injury may result if the pressure exceeds the maximum 110 psi rating.
 4. Stand clear of lift table and depress the UP side of foot valve to raise table.
 5. To lower table, lift detent bar from safety latch and lower to next position or to floor.
 6. Mount ramp to lift top by inserting ramp tabs into slots on lift top.
- NOTE: If cycle vise is being installed, ramp must be mounted opposite the cycle vise.

OPERATION



1. Loads must be centered on table at all times.
- ⚠ 2. Loads must be firmly positioned and secured on table at all times.
3. All moving parts have been lubricated at the factory and should be re-lubricated every 6 months to prevent galling. Grease zerks are located at each end of frame pivot shaft and at top ends of inside frame assembly.
4. Lightly oil cylinder rod when it becomes dry.
5. Squirt some oil through air bleed hole in plate end of cylinder to lubricate piston and its seal every 6 months.
6. Pivot shaft set screws should be checked frequently to be sure they are tight. These are located at the top end of the inside frame assembly.

OTHER OPTIONS AVAILABLE

Separate installation instructions included with each option.

PART #	DESCRIPTION
14476	CV-17 CYCLE VISE - Vise with removable wheel stop built into vise
10728	12" SIDE EXTENSIONS (2) - Expands width of lift from 24" to 48" includes stabilizer bar
16011	13" FRONT EXTENSION - Extends lift top to 93" for longer wheel base motorcycles
10736	13" REAR EXTENSION - Extends lift top to 93" for longer wheel base motorcycles
15566	RAMP END EXTENSIONS - Attaches to end of lift ramp for a more gradual incline to prevent bigger bikes from dragging bottom.
10737	SNOWMOBILE WING KIT - Used when lifting snowmobiles
16355	CE FOOT PEDAL - Covered foot pedal
10732	LIFT DOLLY - Helps move lift while in down position
16010	TOOL TRAY - Keeps tools organized and Handy



REPLACEMENT PARTS

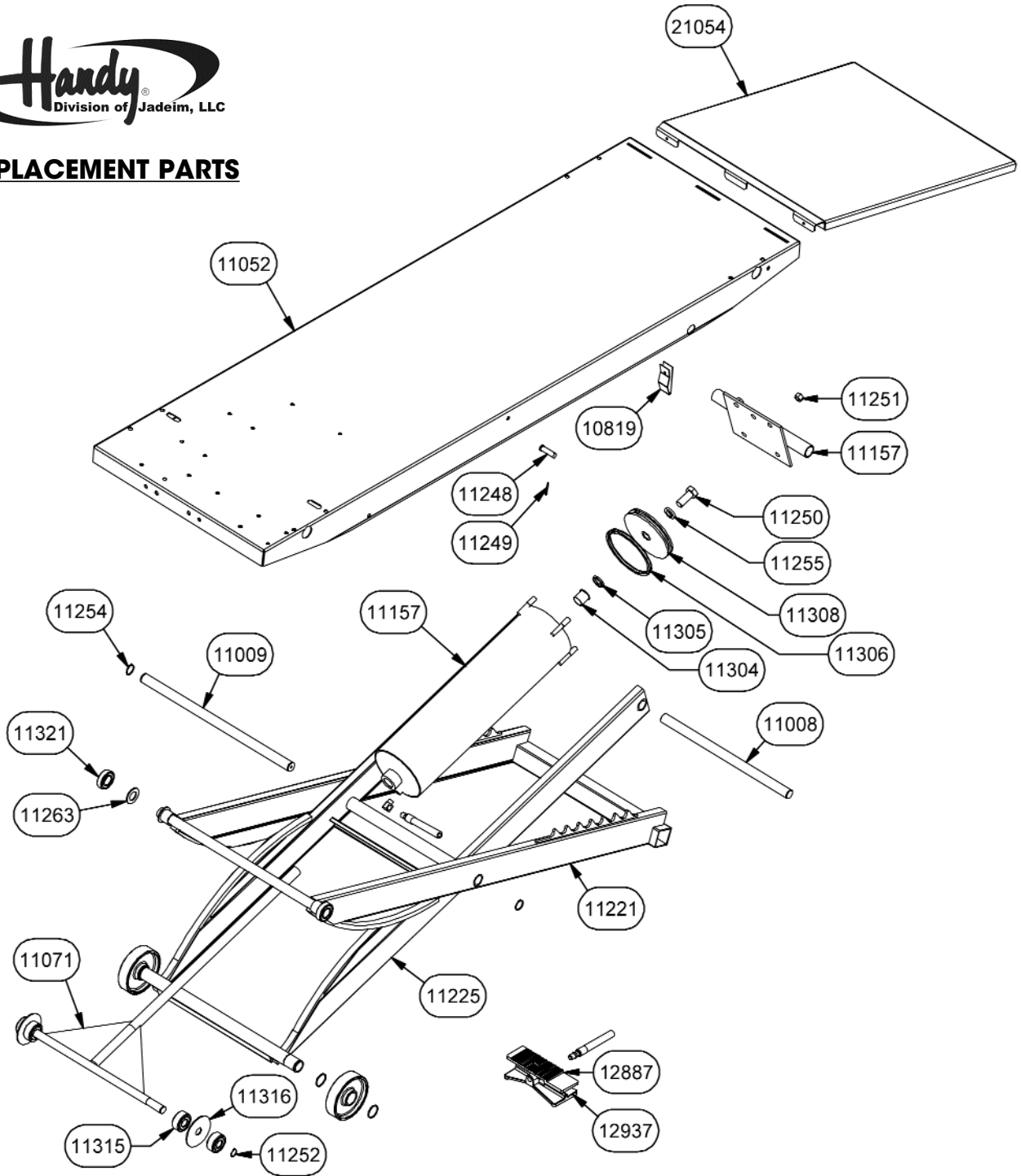

QTY	PART No.	DESCRIPTION	QTY	PART No.	DESCRIPTION
4	11253	RING RETAINING WHEEL 1 5/16 SPIRAL	1	10819	CLIP DETENT BAR
2	11254	RING RETAINING 1	1	11008	SHAFT PIVOT
2	11262	SCREW SET 1/4-20X1/4 SOCK SSS KNL	1	11009	SHAFT FRAME PIVOT
3	11263	WASHER 1 3/4 X 1 1/32 ID MACH	1	11052	TOP ASSEMBLY
4	11303	ZERK GREASE 1/4" DRIVE IN W/BALL	1	11177	DETENT BAR ASSEMBLY
2	11317	HANDLE RED TIP DETENT	1	11215	CYLINDER ASSEMBLY
2	11319	CAST WHEEL	1	11222	OUTSIDE FRAME ASSEMBLY
2	11321	BEARING TRACK ROLLER 1641-2RS	1	11225	INSIDE FRAME ASSEMBLY
1	21054	RAMP ASSEMBLY	2	11248	PIN CLEVIS 1/2 X 1 3/4
			2	11249	PIN COTTER 1/8 X 7/8 PLATED

Recommended maintenance

1. Daily visual checks to be done.
 - A. Check all retaining rings, set screws and working parts are in place and in good working condition before operations
 - B. Check cylinder and foot valves daily for any air leaks before operation.
2. Grease all grease zerks monthly. The locations of these are the two frame center pivot shafts and the two cylinder pivot shaft under the lift top.
3. Oil cylinder every 3 months. Use a combination of 1 oz. of STP engine oil treatment and 2 oz. of air tool oil mixed together and squirt into air cylinder air line. Unscrew foot valve from air line supply , squirt oil into air line then screw foot valve back on air supply line and apply air pressure. This will blow air inside of the cylinder coating the cylinder walls. This procedure keeps seals soft and pliable.

Limited Lifetime Warranty

Handy Industries, Division of Jadeim, LLC is providing a limited lifetime warranty on its motorcycle lift line. This Lifetime Limited Warranty is available on lifts that have a serial number the same as or greater than those listed. Standard 1000 air and electric #ST 0138, SAM 1000 air and electric #S 0082, SAM2 1000 air #S2 0020, BOB 1500 air #B 0100, Electric/Hydraulic 1500 #H 0008, Gruntavore 1800 #GR 0004. The purchaser must provide Handy with a legible copy of the purchase receipt to obtain this warranty. The purchaser must provide Handy notice of the defect and establish that the equipment was properly set up, maintained and operated within the limits of rated and normal usage. Handy Industries, Division of Jadeim, LLC reserves the right to have its product shipped back to the factory for inspection to ensure the lift was not being used above its rated limits and capacity. The purchaser is responsible for freight charges until a determination is made by Handy. Handy will reimburse the purchaser if it is determined that he or she was not using lift above the rated capacity. This warranty covers the structure of the following models of Handy lifts: Standard 1000, SAM 1000, SAM2 1000, BOB 1500, Electric/Hydraulic 1500 and Gruntavore 1800. Attachments for these lift models are not included in the limited lifetime warranty. This warranty only covers the structure of the lift itself. It does not cover any cost of labor, transportation, freight, installation, misuse, abuse, or rust or failure of the air cylinder and/or foot pedal due to rust and or moisture. Also excluded in this warranty are items that were purchased for the Handy lift and installed on it at the factory such as electric motors, hand-held pendants and bearings. Parts considered wearable carry a 90-day warranty. All other parts excluded from the lifetime warranty carry a 1-year warranty from time of purchase. If the lift is purchased from a un-authorized distributor, eBay or other online service, you are not eligible to receive the limited lifetime warranty for the structure of the lift. This warranty is only offered to the original purchaser and is non-transferrable. It must be purchased from Handy Industries, Division of Jadeim, LLC or one of its authorized distributors.



STANDARD ELECTRIC LIFT

WITH PUSHBUTTON CONTROL

P/N 10742

- INSTRUCTIONS ● PARTS DRAWING ● PARTS LIST

WARNING: READ INSTRUCTIONS BEFORE OPERATING

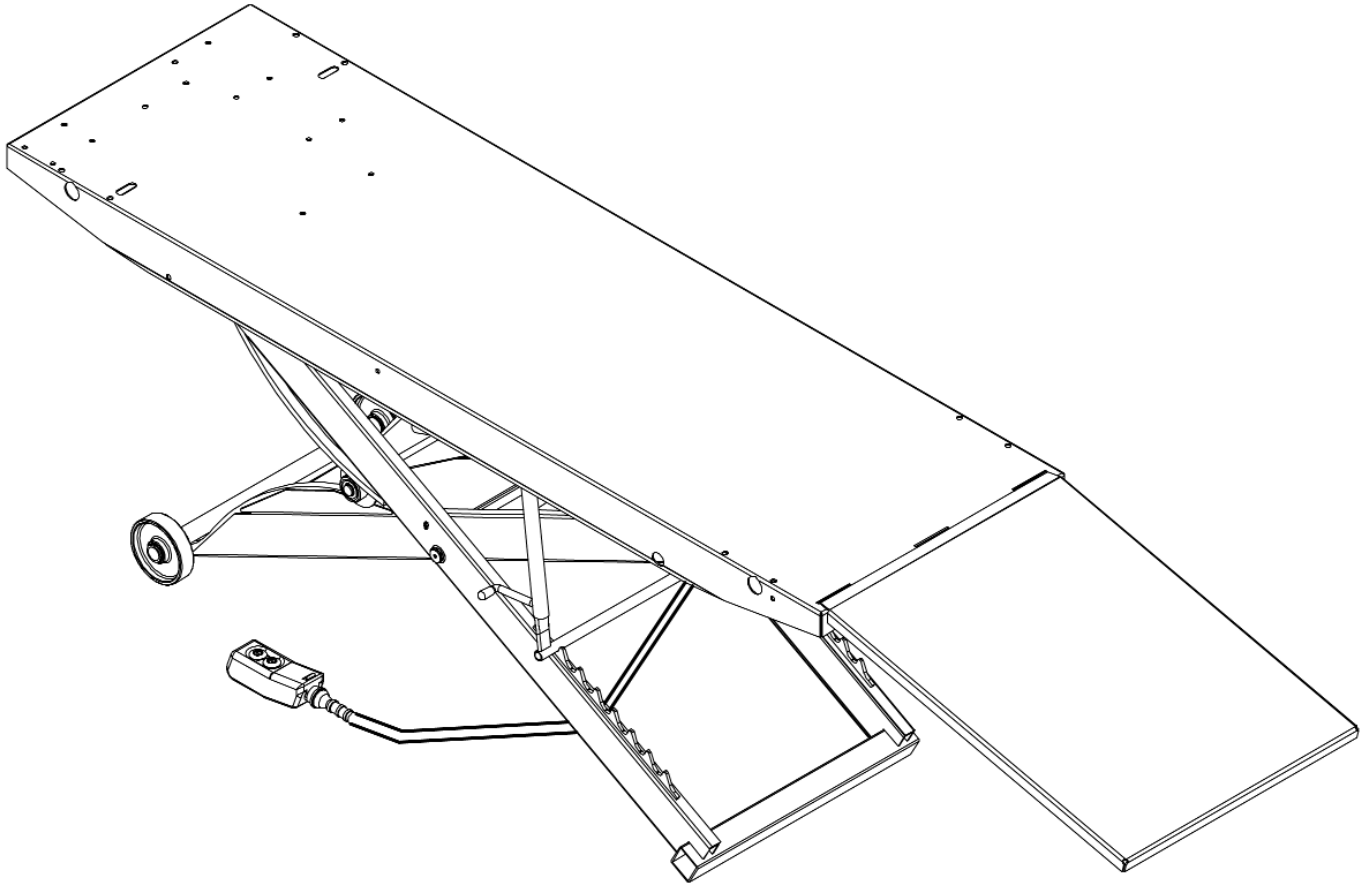

1. This is for the operation on a 115 volt, 60 Hz. circuit only.
2. Do not remove ground prong from plug.
3. Center load on table - 1000 lb. maximum.
4. Keep hands and tools from under carriage.
5. Do not mount table when in elevated position.
6. Do not ride vehicle onto lift.
7. Lift must be in the lowered position when moving.
8. Only trained persons should operate Electric Lift.
9. The working area should be sufficiently lit.
10. Recommended for indoor use only.

HANDY DIVISION OF JADEIM, LLC

401 South 2nd. Marshalltown, IA 50158 Ph: 855-752-5446 Fax 641-752-1205 www.handyindustries.com

STANDARD ELECTRIC LIFT



NOTE: THIS SYMBOL MEANS WARNING OR CAUTION: DEATH, PERSONAL INJURY AND/OR PROPERTY DAMAGE MAY OCCUR UNLESS INSTRUCTIONS ARE FOLLOWED CAREFULLY. READ ENTIRE



POWER SUPPLY

This lift is for operation on 115 volt, 60 Hz current only. Check outlet voltage before plugging in equipment. **WARNING:** This lift is equipped with a 3-prong plug which must be plugged into a grounded 115 volt, 60 Hz power supply for your safety. Removing ground prong from plug or failure to plug into a grounded receptacle may result in a fatal electric shock.

UNPACKING AND SET-UP

1. Open carton, then remove ramp and shipping boards.
2. Keeping hands free of lift mechanisms to avoid personal injury-CAREFULLY turn left over.
3. Mount ramp to lift top by inserting ramp tabs into slots on lift top.

NOTE: If cycle vise is being installed, ramp must be mounted opposite the cycle vise.

OPERATION-LUBRICATION

1. Loads must be centered on table at all times.
2. Loads must be firmly positioned on table at all times.
3. All moving parts have been lubricated at the factory and should be re-lubricated occasionally to prevent galling. Grease zerks are located at each end of frame pivot shaft and at top ends of inside frame assembly.
4. The drive screw, motor and gear box were factory lubricated, and this lubrication should last for the life of the lift. Should re-lubrication be necessary, use a No. 9 multi-purpose gear oil in gear box and an "O" grade gear grease on drive screw.
5. Frame/motor pivot shaft set screws should be checked frequently to be sure they are tight. These are located at the top of the inside frame.

INSTALLING

The drive train components have been burnished in to give a tight, well working fit and will be stiff for the first few cycles. If drive screw should seize, put a few drops of oil on screw and reverse a few times. If motor should pull down or hum, **TURN OFF IMMEDIATELY.** Check to see if drive screw is free.

Other Options Available

Separate installation instructions included with each option

PART #	DESCRIPTION
14476	CV-17 CYCLE VISE - Vise with removable wheel stop built into vise
10728	12" SIDE EXTENSIONS (2) - Expands width of lift from 24" to 48" includes stabilizer bar
16011	13" FRONT EXTENSION - Extends lift top to 93" for longer wheel base motorcycles
10736	13" REAR EXTENSION - Extends lift top to 93" for longer wheel base motorcycles
15566	RAMP END EXTENSIONS - Attaches to end of lift ramp for a more gradual incline to prevent bigger bikes from dragging bottom.
10737	SNOWMOBILE WING KIT - Used when lifting snowmobiles
10732	LIFT DOLLY - Helps move lift while in down position
16010	TOOL TRAY - Keeps tools organized and Handy



STANDARD ELECTRIC LIFT

REPLACEMENT PARTS

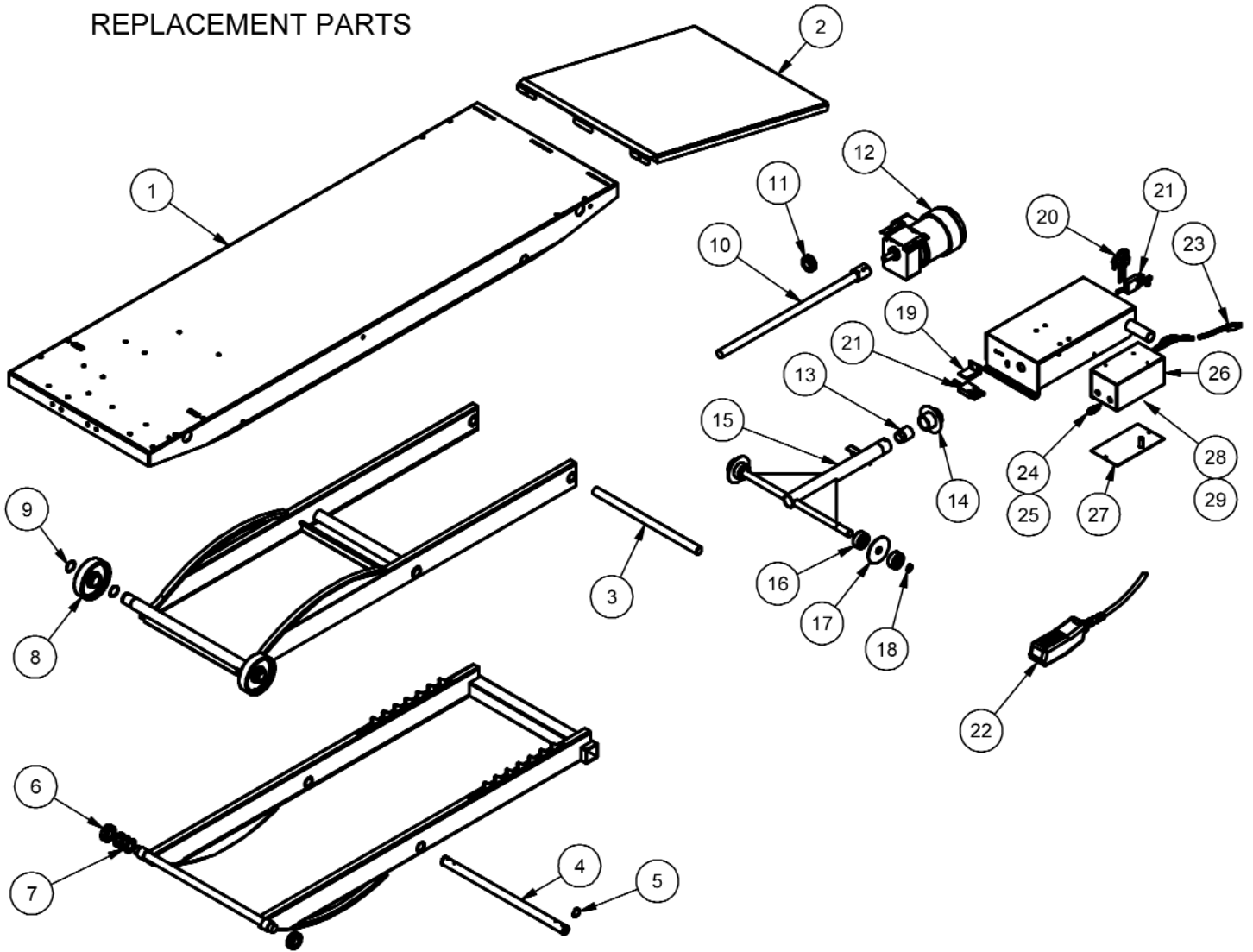

ITEM	PART No.	DESCRIPTION	QTY
1	11052	TOP ASSEMBLY	1
2	21054W	RAMP ASSEMBLY	1
3	11008	SHAFT PIVOT	1
4	11179	FRAME PIVOT SHAFT	1
5	11254	RETAINING RING	2
6	11321	ROLLER TRACK BEARING 1641-2RS	2
7	11263	WASHER 1 3/4 X 1 1/32ID MACH	3
8	14737	CAST WHEEL	2
9	11253	1 5/16 SPIRAL RETAINING RING	4
10	11165	ACME SCREW	1
11	11377	D9 THRUST BEARING	1
12	11323	GEAR MOTOR	1
13	11000	ACME NUT	1
14	11157	ASSY NUT COUPLING WITH LM SW WASHER	1
15	11169	ASSY CAM SHAFT	1

ITEM	PART No.	DESCRIPTION	QTY
16	11315	CAM ROLLER BEARING 5304-2RS	4
17	11316	CAM BRG SPACER 13/16X 1/8X 3 1/2F/W	1
18	11252	CAM BEARING RETAINING RING	2
19	16490	UPPER LIMIT BRACKET	1
20	16876	LOWER LIMIT BRACKET	1
21	16481	LIMIT SWITCH WITH CORD	2
22	20585	CONTROL PENDENT ELECTRIC	1
23	12339	CORD POWER 14/3 STO 105DEG 6FT	1
24	16482	PANEL MOUNT FUSEHOLDER	1
25	16483	TIME DELAY FUSE	1
26	16885	CONTROL BOX ASSY	1
27	16880	CONTROL BOX LID ASSY	1
28	16479	CONTACTOR (INSIDE CONTROL BOX)	1
29	16480	RELAY (INSIDE CONTROL BOX)	1

STANDARD ELECTRIC LIFT

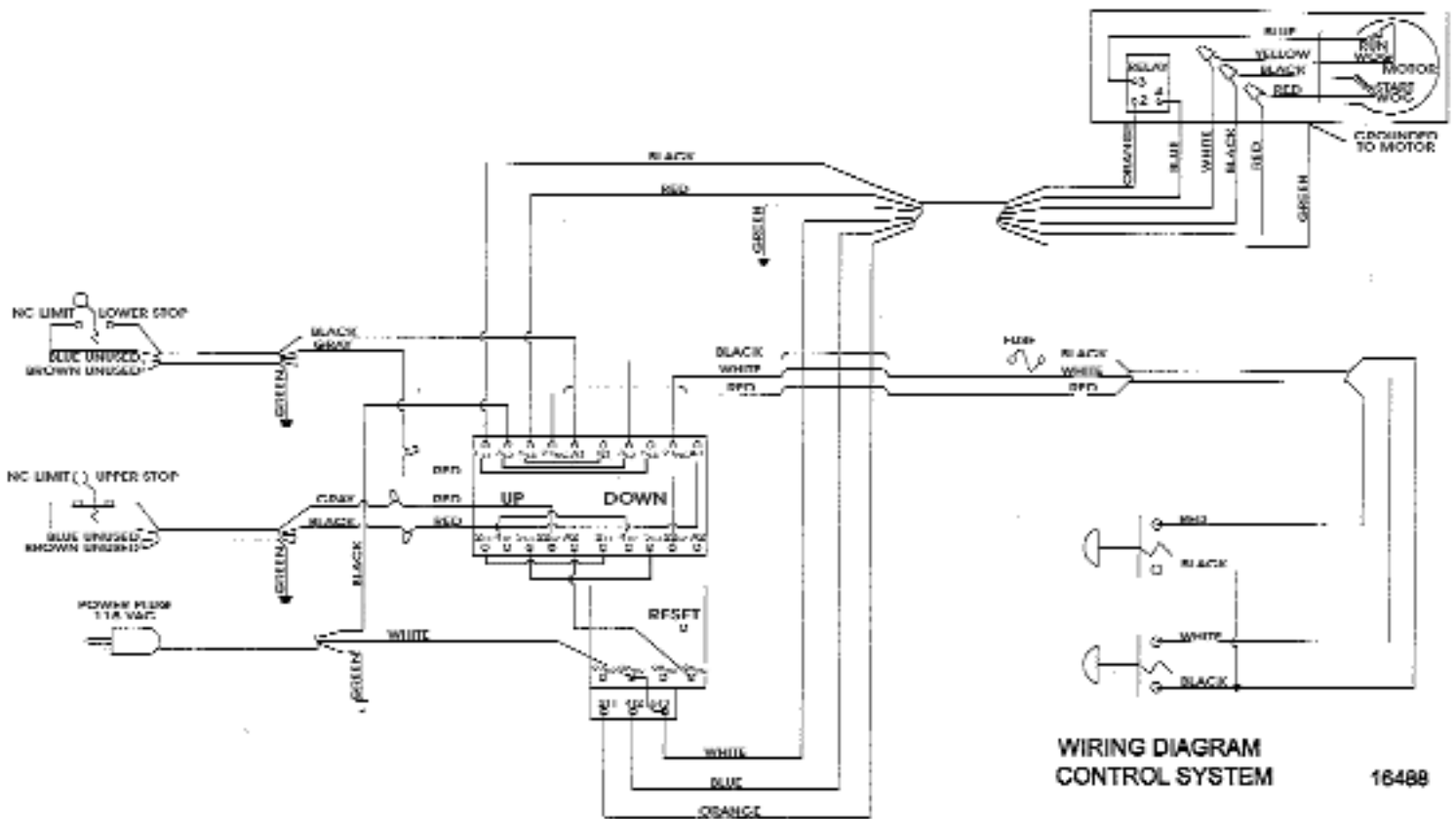

Limited Lifetime Warranty

Handy Industries, Division of Jadeim, LLC is providing a limited lifetime warranty on its motorcycle lift line. This Lifetime Limited Warranty is available on lifts that have a serial number the same as or greater than those listed. Standard 1000 air and electric #ST 0138, SAM 1000 air and electric #S 0082, SAM2 1000 air #S2 0020, BOB 1500 air #B 0100, Electric/Hydraulic 1500 #H 0008, Gruntavore 1800 #GR 0004. The purchaser must provide Handy with a legible copy of the purchase receipt to obtain this warranty. The purchaser must provide Handy notice of the defect and establish that the equipment was properly set up, maintained and operated within the limits of rated and normal usage. Handy Industries, Division of Jadeim, LLC reserves the right to have its product shipped back to the factory for inspection to ensure the lift was not being used above its rated limits and capacity. The purchaser is responsible for freight charges until a determination is made by Handy. Handy will reimburse the purchaser if it is determined that he or she was not using lift above the rated capacity. This warranty covers the structure of the following models of Handy lifts: Standard 1000, SAM 1000, SAM2 1000, BOB 1500, Electric/Hydraulic 1500 and Gruntavore 1800. Attachments for these lift models are not included in the limited lifetime warranty. This warranty only covers the structure of the lift itself. It does not cover any cost of labor, transportation, freight, installation, misuse, abuse, or rust or failure of the air cylinder and/or foot pedal due to rust and or moisture. Also excluded in this warranty are items that were purchased for the Handy lift and installed on it at the factory such as electric motors, hand-held pendants and bearings. Parts considered wearable carry a 90-day warranty. All other parts excluded from the lifetime warranty carry a 1-year warranty from time of purchase. If the lift is purchased from a un-authorized distributor, eBay or other online service, you are not eligible to receive the limited lifetime warranty for the structure of the lift. This warranty is only offered to the original purchaser and is non-transferrable. It must be purchased from Handy Industries, Division of Jadeim, LLC or one of its authorized distributors.

STANDARD ELECTRIC LIFT CONTROL SYSTEM

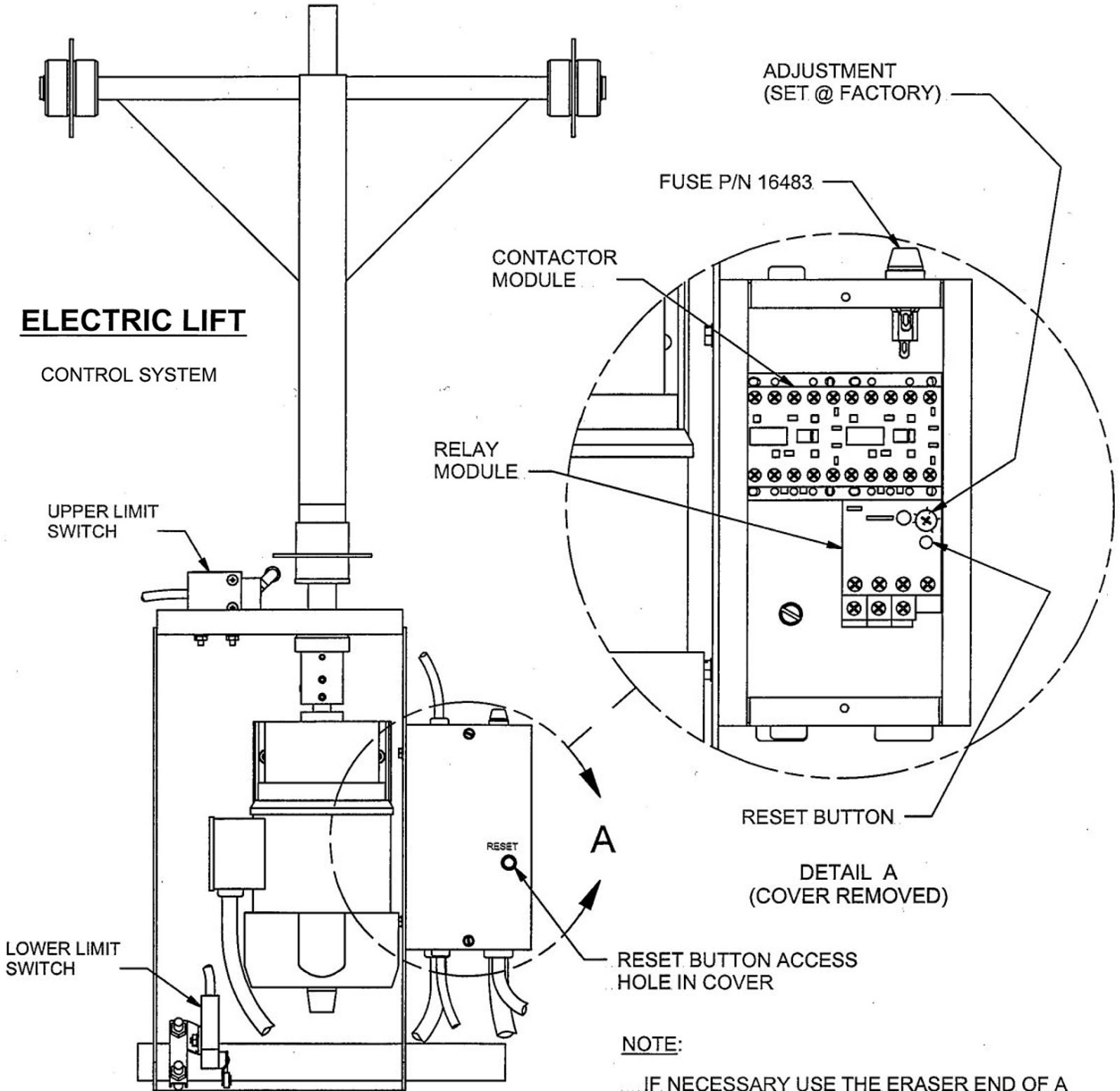

NOTE:

... IF NECESSARY USE THE ERASER END OF A
... COMMON WOODEN PENCIL TO PUSH DOWN
... ON THE RESET BUTTON